

## 7 Datasheet for five products

5 Products, 40 l/min, Suction or STP, with Vapour Recovery and Preset

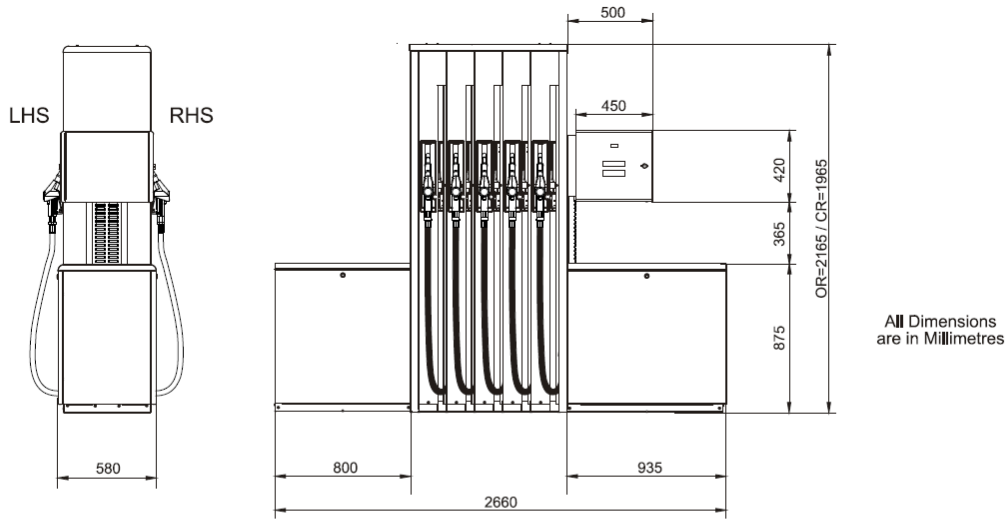

All Dimensions are in Millimetres

Option: Suction connection kit  
140 826 683 For GPU-90 & GPU-140

## Footprint Details

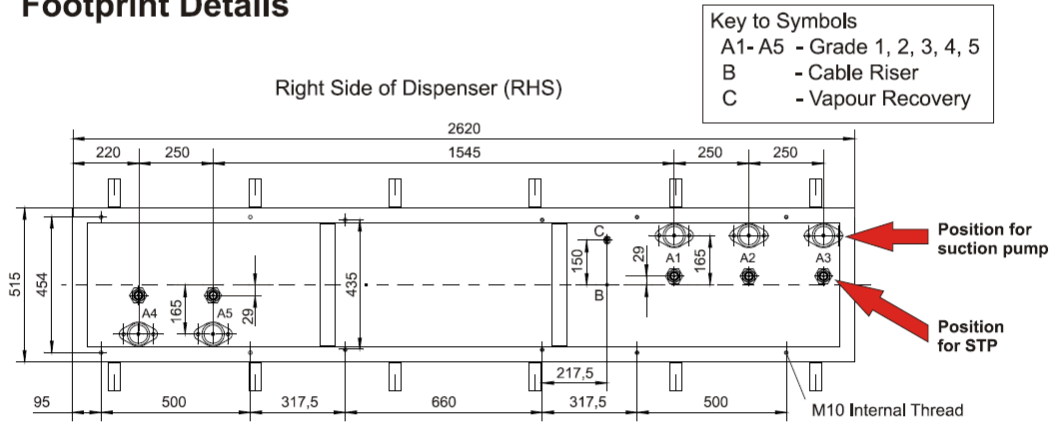

Key to Symbols  
A1- A5 - Grade 1, 2, 3, 4, 5  
B - Cable Riser  
C - Vapour Recovery

Subframe  
Part No. - 140 875 131

Left Side of Dispenser (LHS)

It is recommended that Vapour Recovery return pipes are installed where this may be a future requirement.

## Module Configuration and Maximum Current

Suction Pump	Submerge Turbine Pump (STP)
<u>Motor supply, maximum current</u>	<u>Vapour Recovery, maximum current</u>
1 Phase Versions, 230V = 12,5 Amps	3 Phase Motors = 1,0 Amps
3 Phase Versions, 230V = 10,5 Amps	1 Phase Motors = 3,0 Amps
3 Phase Versions, 400V = 6,0 Amps	<u>Electronic supply, maximum current</u>
<u>Electronic supply, maximum current</u>	All Versions = 3,0 Amps
All Versions = 3,0 Amps	

